

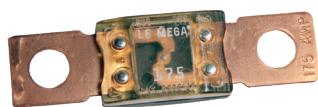

MEGA® Fuses



MEGA® Clear Top Housing Fuse

## MEGA® and MEGA® Clear Top Fuse Rated 32V

The MEGA® Fuse is designed for high current circuit protection up to 500A with “Diffusion Pill Technology.” The MEGA® Fuse also provides time delay characteristics. Designed and patented by Littelfuse, the MEGA® Fuse is ideal for battery and alternator protection application and other heavy gauge cables requiring ultra-high current protection.

### Specifications

Voltage Rating:	32 VDC
Interrupting Rating:	2000A @ 32 VDC
Recommended Environmental Temperature:	-40°C to + 125°C
Terminals Materials:	Copper (Silver plated copper available)
Housing Material:	PPA-GF33HS (U.L. 94 Flammability rating - HB)
Clear Top Housing Material:	PES (top) (U.L. 94 Flammability rating - V0) PPA-GF33HS (bottom) (U.L. 94 Flammability rating - HB)
Mounting Torque M6:	8-14 Nm
Mounting Torque M8:	12-18 Nm
Complies with:	ISO 8820-5



### Ordering Information

Part Number	Rating	Package Size	Plating	Bolt Size	Bolt Hole Qty
0298xxx.ZXEH	80 - 250	500	None	M8	2
0298xxx.ZXH	300 - 500	500	None	M8	2
0298xxx.UX1M8	80 - 500	500	None	M8	1
0298xxx.ZXB	40 - 250	500	Ag	M8	2
0298xxx.ZXA	80 - 500	500	None	M6	2
0298xxx.UXT	40 - 250	500	None	M8	2

### Time-Current Characteristics

% of Rating	Opening Time Min / Max (s)	
	40-250	300-500
75	- / -	14,400 / ∞
100	14,400 / ∞	- / -
135	120 / 1800	- / -
200	1 / 15	1 / 15
350	0.3 / 5	0.5 / 5
600	0.1 / 1	0.1 / 1

### Time-Current Characteristic Curves

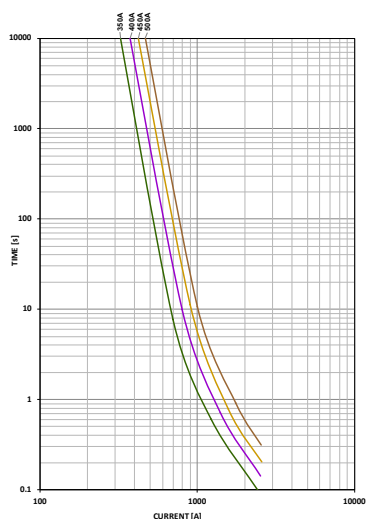
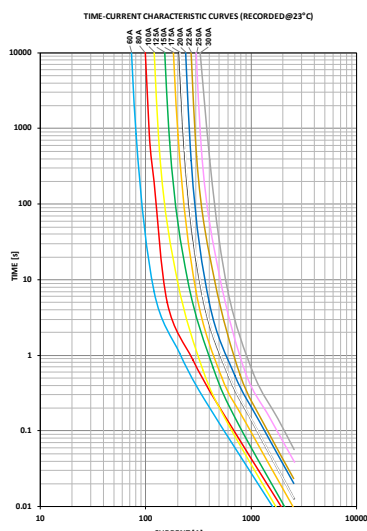

### MEGA Clear Top Housing Material Fuse

0298xxx.UXT	40 - 250	500	None	M8	2
-------------	----------	-----	------	----	---

### Ratings

Part Number	Current Rating (A)	Color Code <sup>3</sup>	Test Cable Size (mm <sup>2</sup> )	Typ. Voltage Drop (mV)	Typ. Cold Resistance (mΩ)	Typ. I <sup>2</sup> t (A <sup>2</sup> s)
0298040._1	40	-	4	132	2.51	8,700
0298060._1	60	-	6	119	1.50	21,000
0298080._	80	Red	10	87	0.72	21,500
0298100._	100	Yellow	16	87	0.56	31,100
0298125._	125	Green	16	80	0.42	57,800
0298150._	150	Orange	25	92	0.35	100,000
0298175._	175	White	25	86	0.29	168,000
0298200._	200	Blue	35	83	0.26	204,000
0298225._	225	Brown	35	82	0.22	257,000
0298250._	250	Pink	50	82	0.20	389,000
0298300._2	300	Grey	70	74 <sup>4</sup>	0.17	315,000
0298350._2	350	Dark Green	70	68 <sup>4</sup>	0.14	500,000
0298400._2	400	Purple	70	64 <sup>4</sup>	0.13	610,000
0298450._2	450	Light Yellow	70	60 <sup>4</sup>	0.11	1,050,000
0298500._2	500	Brown	70	58 <sup>4</sup>	0.09	2,050,000

1: Not mentioned in ISO standards  
 2: Short Circuit Protector only  
 3: 0298xxx.ZXB has white font color on all ratings.  
 4: Voltage Drop measurements for short circuit protectors taken at 75% of rated current.

The typical I<sup>2</sup>t is an average value calculated from the breaking capacity tests by using the melting time before the arcing occurs.

### REV07272021

Littelfuse® products are not designed for, and shall not be used for, any purpose (including, without limitation, automotive, military, aerospace, medical, life-saving, life-sustaining or nuclear facility applications, devices intended for surgical implant into the body, or any other application in which the failure or lack of desired operation of the product may result in personal injury, death, or property damage) other than those expressly set forth in applicable Littelfuse® product documentation. Warranties granted by Littelfuse® shall be deemed void for products used for any purpose not expressly set forth in applicable Littelfuse® documentation. Littelfuse® shall not be liable for any claims or damages arising out of products used in applications not expressly intended by Littelfuse® as set forth in applicable Littelfuse® documentation. The sale and use of Littelfuse® products is subject to Littelfuse Terms and Conditions of Sale, unless otherwise agreed by Littelfuse®.

## MEGA® Fuse Rated 32V

### Dimensions

Dimensions in mm for reference only.  
See outline drawing for dimensions and tolerances.

#### ZX & UXT Versions

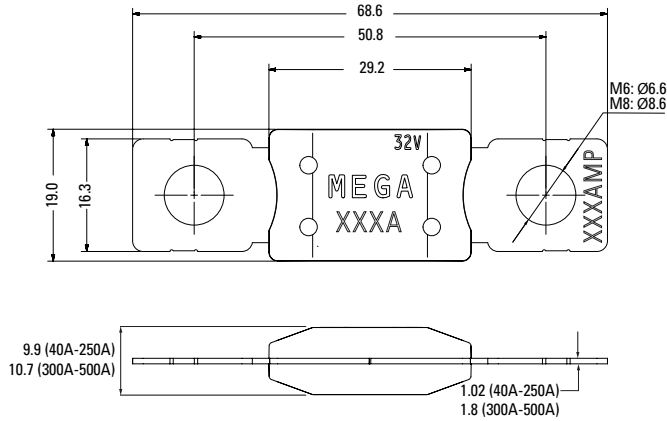

#### UX1M8 Version

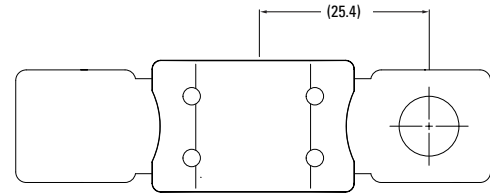

### Typical Derating

Temperature Security Margin is 20%  
Please contact Littelfuse® for Details Regarding Derating Test Set-Up.

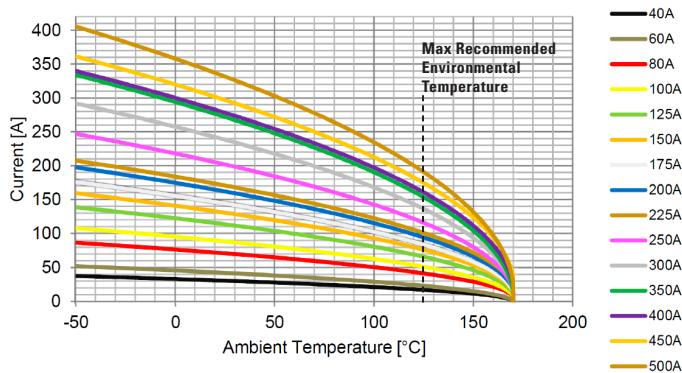

Derating curves may change depending on the final condition of the application (terminals characteristics, wire size etc.).  
Please ask Littelfuse for more information.

### Temperature Table

max. allowed current load [A] at ambient temperature								
	-20°C	0°C	20°C	65°C	85°C	95°C	105°C	125°C
<b>40A</b>	35	33	31	26	23	22	20	17
<b>60A</b>	48	46	43	36	32	30	28	23
<b>80A</b>	81	76	72	61	55	52	49	41
<b>100A</b>	101	95	90	76	69	65	61	51
<b>125A</b>	129	123	116	98	88	83	78	66
<b>150A</b>	149	141	133	112	102	96	90	76
<b>175A</b>	164	156	147	124	112	106	99	84
<b>200A</b>	184	175	165	139	126	119	112	94
<b>225A</b>	194	184	174	147	134	127	119	101
<b>250A</b>	230	218	205	173	157	147	138	116
<b>300A</b>	272	258	242	204	184	174	162	136
<b>350A</b>	311	294	277	232	209	197	184	154
<b>400A</b>	317	300	283	239	216	204	191	161
<b>450A</b>	337	320	302	256	232	219	206	175
<b>500A</b>	378	358	337	284	257	242	227	191

REV07272021

Littelfuse® products are not designed for, and shall not be used for, any purpose (including, without limitation, automotive, military, aerospace, medical, life-saving, life-sustaining or nuclear facility applications, devices intended for surgical implant into the body, or any other application in which the failure or lack of desired operation of the product may result in personal injury, death, or property damage) other than those expressly set forth in applicable Littelfuse® product documentation. Warranties granted by Littelfuse® shall be deemed void for products used for any purpose not expressly set forth in applicable Littelfuse® documentation. Littelfuse® shall not be liable for any claims or damages arising out of products used in applications not expressly intended by Littelfuse® as set forth in applicable Littelfuse® documentation. The sale and use of Littelfuse® products is subject to Littelfuse Terms and Conditions of Sale, unless otherwise agreed by Littelfuse®.